

**HB
PRECAST**

REVISIONS
DATE

Company

HB PRECAST
594 West Elma Hicklin rd
McCleary WA, 98557
(360) 495-4156

SHEET TITLE
**1 250 GAL
LARGE
SEPTIC TANK**

SHEET DATA
DRAWN BY: GW
CHECKED BY:
SCALE: 1" = 1'-0"
DATE: 12-01-22
PROJECT:

SHEET NUMBER
A1
1 0 1

Note: 1. All TANKS COME WITH 1 2" TALL RISER PIPE AT THE 24" OPENINGS.

2. RISER LIDS NOT INCLUDED

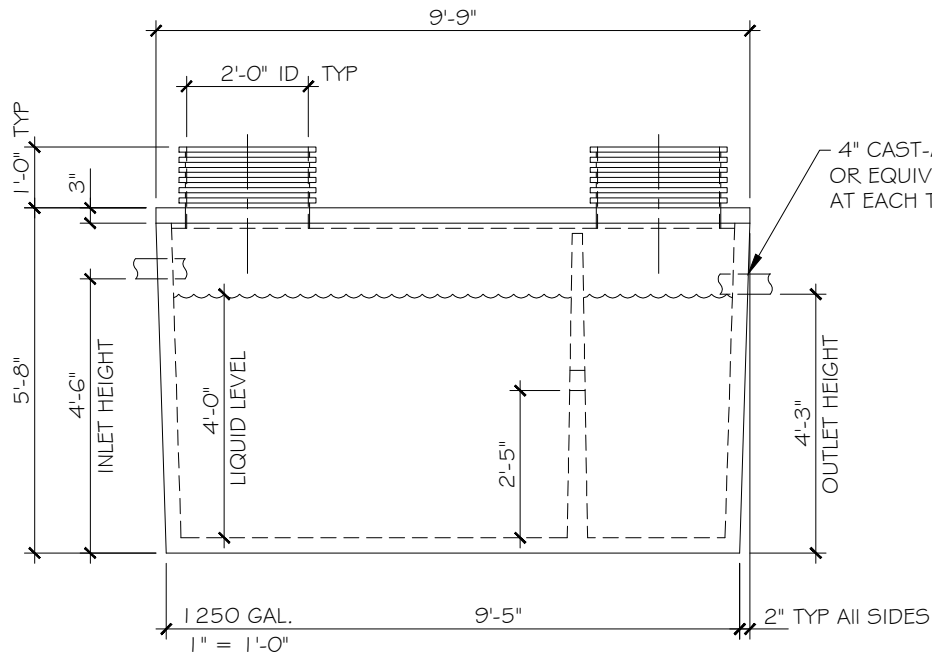

4" CAST-A-SEAL GASKET
OR EQUIV. WATER-TIGHT
AT EACH TANK PERFORATION. TYP.



4" PASS THROUGH